

# Catalogue No: **IA08BLF15PCM1**

## INDUCTIVE STAINLESS STEEL LONG M8 DC PNP NC 1.5mm+5M M12 CAB

Field Switching and Sensing > Non Contact Sensors > Proximity Sensors > Carlo Gavazzi Proximity Sensors > Carlo Gavazzi Discrete Inductive Proximity Sensors > Cylindrical 8mm Miniature - Inductive Sensors



IA Series Inductive Proximity Sensors, flush type, stainless steel M8 long housing, 10 to 30 V DC power supply, PNP NC output, 1.5mm sensing range, IP67 rating, M12 Plug, with 5m cable included



- Cylindrical housing from 4 to 30mm
- Both digital (SCR, transistor) and analogue outputs.
- Standard and extended sensing distance
- Flat-pack housing Stainless steel and Polyester housing Flush / Non flush versions

Representative Photo Only  
(actual product may vary based on configuration selections)

### SPECIFICATIONS

Product Series	IA
Component Type Field Switching & Sensing	Proximity Sensor
Sensing Mode	Inductive
Shielded	Yes
Shape	Cylindrical - Threaded
Diameter	8 mm
Length	70 mm
Orientation	Straight Through
Mounting (Multiple)	Flush Mount Mounting Nuts (Included)
Teach Mode / Sensitivity Adjustment	No sensitivity
Sensing Distance	1.5 mm
Ue, Rated Operational Voltage, DC, min	10 V DC
Ue, Rated Operational Voltage, DC, max	30 V DC
Switching Mode	N/C
Output Type	PNP
Switching/Operating Frequency	2000 Hz
Number of Conductors	3 qty
Connection / Termination	M12 x 1, DC Micro, 4-pin
Material, Body / Housing	Stainless Steel material
Operating Temperature, Max	70 °C max
Operating Temperature, Min	-25 °C min
Storage Temperature, Max	75 °C max
Storage Temperature, Min	-30 °C min
IP Rating	IP67

# Catalogue No: **IA08BLF15PCM1**

## INDUCTIVE STAINLESS STEEL LONG M8 DC PNP NC 1.5mm+5M M12 CAB

Field Switching and Sensing > Non Contact Sensors > Proximity Sensors > Carlo Gavazzi Proximity Sensors > Carlo Gavazzi Discrete Inductive Proximity Sensors > Cylindrical 8mm Miniature - Inductive Sensors



### REFERENCES

IECEX Certificate -

Supplier Declaration of Conformity: -

Installation Guide: -

User Manual: -

Manufacturer Datasheet: [IA08BLF15NCM1\\_ManufacturerDatasheet](#)

Manufacturer Catalogue & Product Selection: -

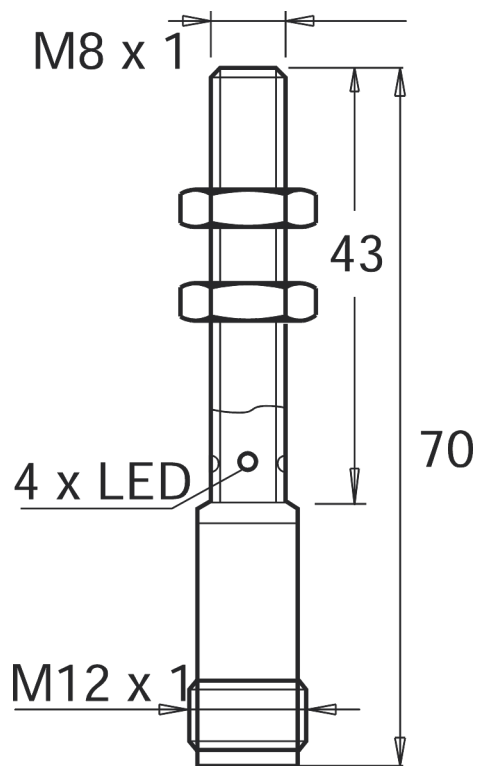

Dimension Diagram

Catalogue No: **IA08BLF15PCM1**

**INDUCTIVE STAINLESS STEEL LONG M8 DC PNP NC 1.5mm+5M M12 CAB**

Field Switching and Sensing > Non Contact Sensors > Proximity Sensors > Carlo Gavazzi Proximity Sensors > Carlo Gavazzi Discrete Inductive Proximity Sensors > Cylindrical 8mm Miniature - Inductive Sensors

